

J.BURROWS

• • • • •

ASSEMBLY INSTRUCTIONS

SHELVING

5 SHELF UNIT

JB5TRHDSR

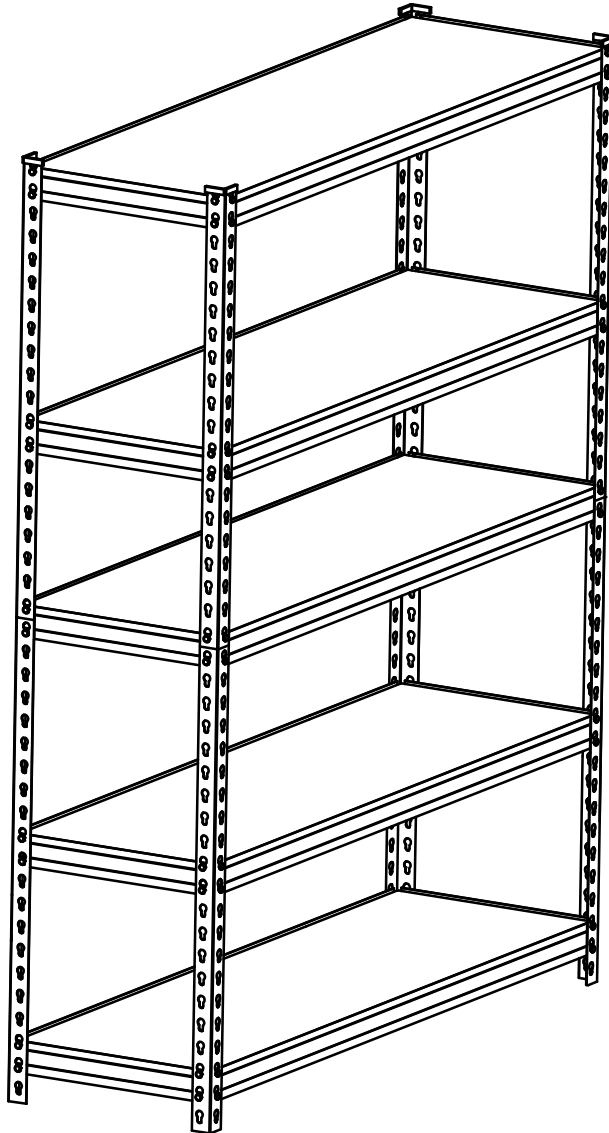

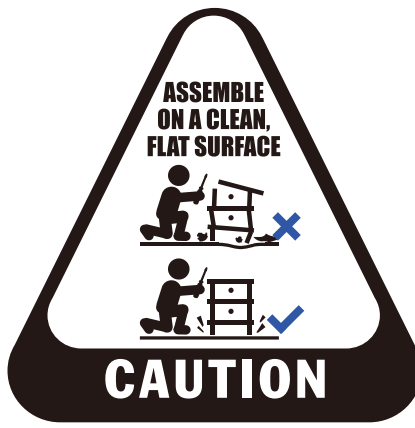

Tools Required

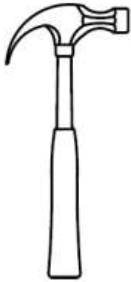

Hardware List

PARTS INVENTORY CHECKLIST

	5 Shelf
A Posts	8
B Shelves	8
C Beams	8
D Braces	8
E Post Caps	8

Alternative assembly configurations:

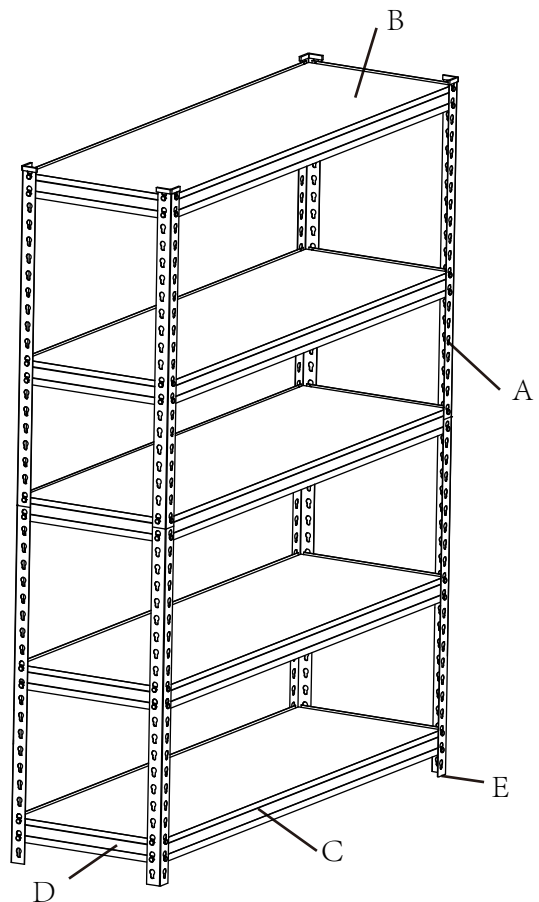
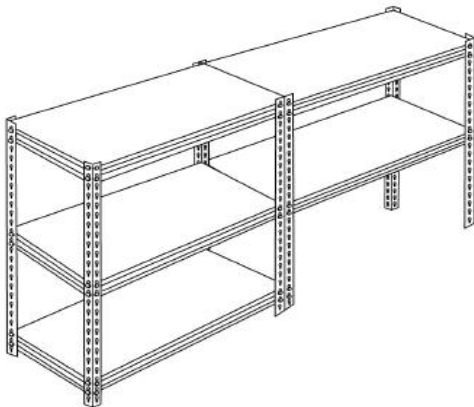

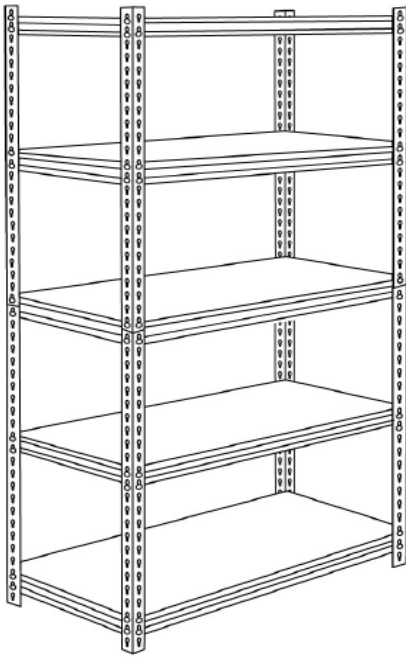

FOR SAFETY

- BE CAREFUL of sharp edges when assembling.
 - DO NOT stand on this product or use as a ladder.
 - DO NOT alter this product in any manner that is not intended. This may cause product damage or personal injury.
 - Position the product on a level surface.
- The maximum loaded weight for each shelf is no more than **350kg**, evenly distributed.

When loading shelves, place heavier items on the lower shelves, distributing the load evenly.

Fasten the unit to the wall whenever possible with proper fasteners (not provided).

183cm H x 122cm W x 61cm D

1

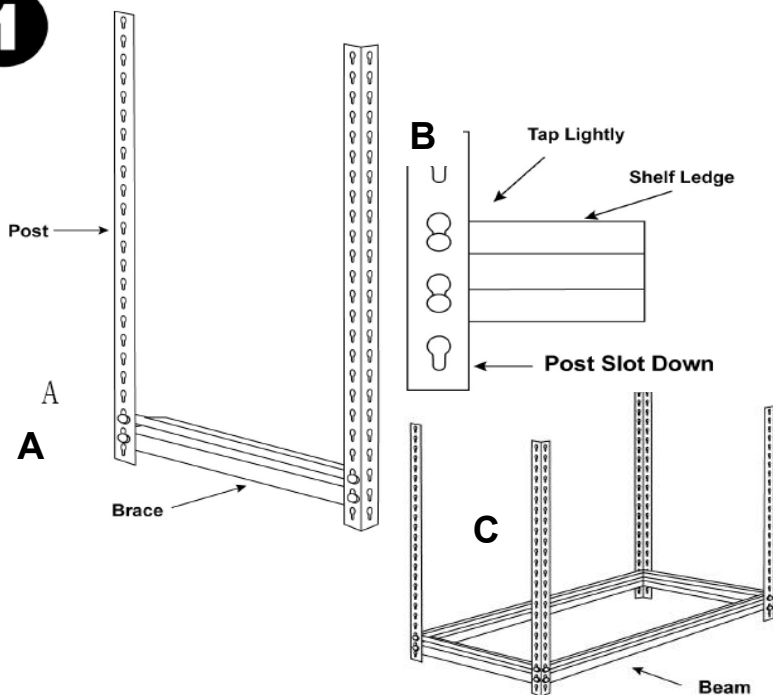

Assembly is done by fitting the rivets of the beams and braces into the post slots. Assemble two (2) posts with one (1) brace. Skipping one slot from the bottom of the post (**A**), place the rivets into post with the slot pointing down, and with the shelf ledge of the brace facing up (**B**). Tap lightly with rubber mallet being sure the rivets are straight when seating into slots. Repeat with two (2) post and one (1) brace. Assemble the two post units with two beams (**C**). Skip one hole from the bottom of post, tap lightly to seat rivets.

2

Start by adding a shelf to the level previously built, then continue working by adding the second level using two (2) beams and two (2) braces in the post slots of your desired location.

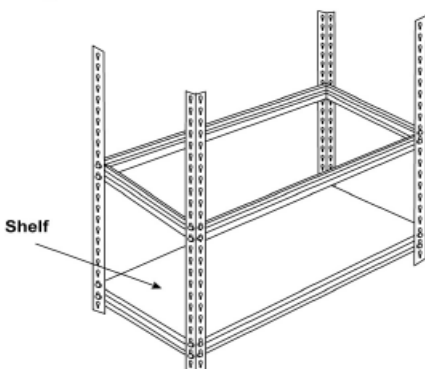

Again place the rivets of the beams and braces into the post slots with the shelf ledge facing up and tap lightly to seat the rivets.

Add a shelf to the previously built level, then assemble the top post to the bottom post by using two (2) beams and two (2) braces. One (1) rivet from each beam and brace must be placed in the top hole of the bottom post and the bottom hole of the top post (**D**)

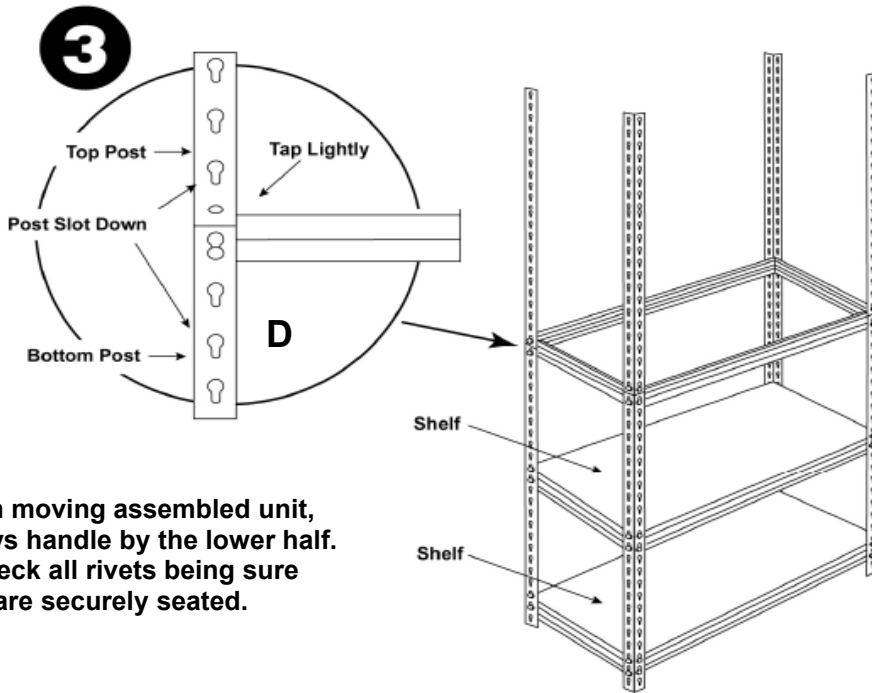

When moving assembled unit, always handle by the lower half. Recheck all rivets being sure they are securely seated.

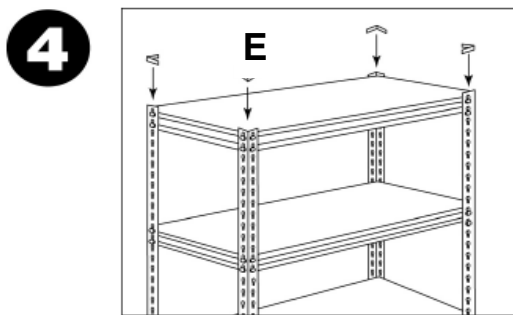

Horizontal Assembly

First and second slots recommended

Optional Location

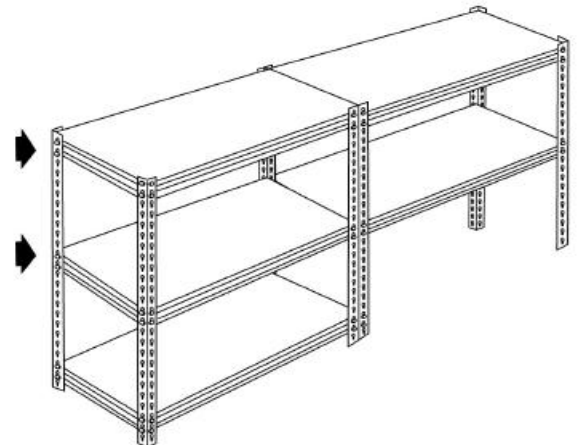

Add a shelf to the previously built level, then continue by adding the fourth and fifth level to the unit using two beams and two braces per level. Tap lightly to properly seat the rivets and add the final shelves to the unit. Install all four end caps to the top of the unit after assembly has been completed (E). Install end caps to post by pressing down on ends.

For damaged or missing parts, please email products@geelongsales.com.au